

UNIVERSITY OF FORT HARE

ELEMENTARY MECHANICS

PHY 115F

DEGREE EXAMINATIONS

May / Jun

YEAR

2025

Time: 2 hours
Subject: PHY 115F
Marks: 100

This paper consists of 6 pages, including the cover page

Internal Examiners

Ms. Y. Mapantsela

Moderator

Mr. T. Mthimunye

INSTRUCTIONS

Answer ALL Questions.

Show ALL your calculations

Useful information on the back page.

Round off your answers to TWO decimal places.

Question 1

1.1 Suppose we are told that the acceleration a of a particle moving with uniform speed v in a circle of radius r is proportional to some power of r , say r^n , and some power of v , say v^m . Determine the values of n and m write the simplest form of an equation for the acceleration. (4)

1.2 Show that the following formulas are dimensionally correct:

(a) $T = 2\pi\sqrt{\frac{l}{g}}$ where $l = [L] = m$ and $g = a = [L]/[T]^2$ (3)

(b) $v = \sqrt{\frac{Fl}{m}}$ where $F = \text{force}$ and $m = \text{mass}$ (3)

1.3 Convert the following:

(a) Convert 60 m/s to km/hr. (3)

(b) Convert $1.65 \times 10^3 \text{ kg/m}^3$ to g/cm^3 (3)

(c) Use **only** units to prove that $\frac{1}{2}mv^2 = mgh$ (4)

Question 2

2.1 Add the vectors **A**, **B** and **C** shown in the figure using the component method. Magnitudes of vectors are $A = 12.0\text{m}$, $B = 12.0\text{m}$ and $C = 12.0\text{m}$. find the resulting displacement. (10)

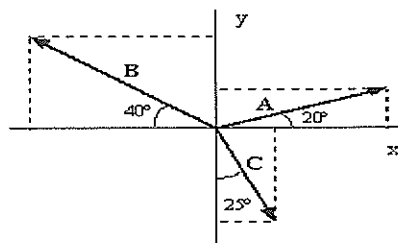

(10)

2.2 Find the sum of two displacement vectors \vec{A} and \vec{B} lying in the xy plane and given by

$$\vec{A} = (2.0\hat{i} + 2.0\hat{j}) \text{ m and } \vec{B} = (2.0\hat{i} - 4.0\hat{j}) \text{ m} \quad (3)$$

2.3 A particle undergoes three consecutive displacements: $\Delta r_1 = (15\hat{i} + 30\hat{j} + 12\hat{k}) \text{ cm}$ $\Delta r_2 = (23\hat{i} - 14\hat{j} - 5.0\hat{k}) \text{ cm}$ $\Delta r_3 = (-13\hat{i} + 15\hat{j}) \text{ cm}$. Find unit-vector notation for the resultant displacement and its magnitude. (2)

2.4 A hiker begins a trip by a first walking 25.0 km southeast of her car. She stops and sets up her tent for the night. On the second day, she walks 40.0 km in a direction 60.0° north of east, at which point she discovers a forest ranger's tower.

(a) Determine the components of the hiker's displacement for each day and the components of the hiker's resultant displacement \vec{R} for the trip. Find an expression for \vec{R} in terms of unit vectors. (5)

Question 3

3.1 A stone thrown from the top of a building is given an initial velocity of 20.0 m/s straight upward. The stone is launched 50.0m above ground, and the stone just misses the edge of the roof on its way down as shown in the figure below,

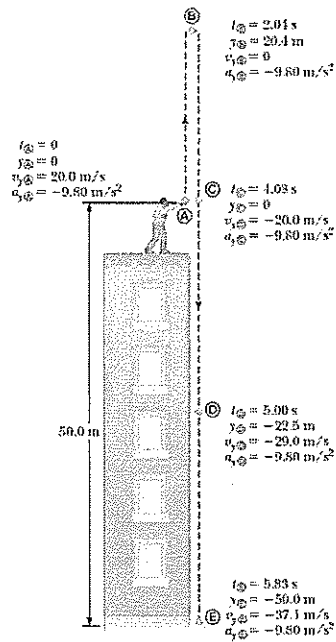

- Using $t_A = 0$ as the time the stone leaves the thrower's hand at position A, determine the time at which the stone reaches its maximum height.
- Find the maximum height of the stone.
- Determine the velocity of the stone when it returns to the height from which it was thrown.
- Find the velocity and the position of the stone at $t = 5.00\text{s}$. (10)

Question 4

4.1 A displacement vector has a magnitude of $r = 175 \text{ m}$ and points at an angle of 50.0° relative to the x axis in Figure 1.20. Find the x and y components of this vector. (2)

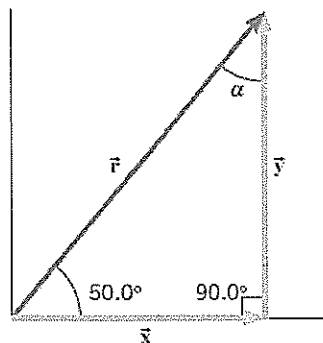

Figure 1.20 The x and y components of the

4.2 A jogger runs 145m in a direction 20.0° east of north (displacement vector \vec{A}) and then 105m in a direction 35.0° south of east (displacement vector \vec{B}). Using components determine the magnitude and direction of the resultant vector \vec{C} for these two displacements. (6)

4.3 Find the sum, magnitude, and direction of two displacement vectors \mathbf{A} and \mathbf{B} lying in the xy plane and given by $\mathbf{A} = (2.0 \mathbf{i} + 2.0 \mathbf{j})$ m and $\mathbf{B} = (2.0 \mathbf{i} - 4.0 \mathbf{j})$ m. (5)

4.4 Find the components of vector $\mathbf{A} = 5.0$ m, $\theta = 30^\circ$ (2)

4.5 A man cleaning a floor pulls a vacuum cleaner with a force of magnitude $F = 50.0$ N at an angle of 30.0° with the horizontal (Fig. 7.5). Calculate the work done by the force on the vacuum cleaner as the vacuum cleaner is displaced 3.00 m to the right. (2)

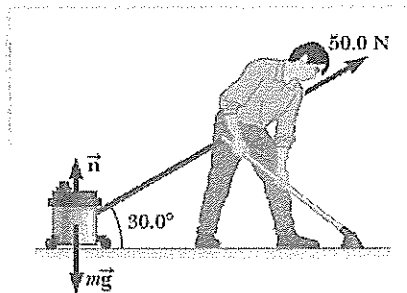

Figure 7.5 (Example 7.1) A vacuum cleaner being pulled at an angle of 30.0° from the horizontal.

4.6 The vectors \vec{A} and \vec{B} are given by $\vec{A} = (2\hat{i} + 3\hat{j})$ and $\vec{B} = (-\hat{i} + 2\hat{j})$.

(a) Determine the scalar product $\vec{A} \cdot \vec{B}$ (2)

(b) Find the angle θ between \vec{A} and \vec{B} (4)

4.7 A particle moving in the xy plane undergoes a displacement given by $\Delta\mathbf{r} = (2.0\hat{i} + 3.0\hat{j})$ m as a constant force $\mathbf{F} = (5.0\hat{i} + 2.0\hat{j})$ N acts on the particle.

(a) Calculate magnitude of the displacement and the force. (2)

(b) Calculate the work done by \mathbf{F} on the particle. (3)

Question 5

5.1 A stone is thrown from the top of a building upward at an angle of 30.0° to the horizontal with an initial speed of 20.0 m/s as shown in the diagram. The height from which the stone is thrown is 45.0 m above the ground.

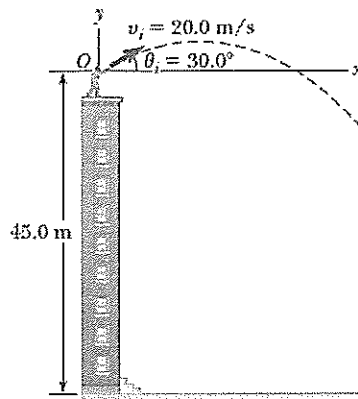

- (a) How long does it take the stone to reach the ground? (4)
- (b) What is the speed of the stone just before it strikes the ground? (3)

5.2 Newton's second law. (3)

5.3 Two people are pushing a stalled car, as Figure 4.5a indicates. The mass of the car is 1850 kg. One person applies a force of 275 N to the car, while the other applies a force of 395 N. Both forces act in the same direction. A third force of 560 N also acts on the car, but in a direction opposite to that in which the people are pushing. This force arises because of friction and the extent to which the pavement opposes the motion of the tires.

- (a) Draw a free body diagram of the horizontal forces acting on the car. (3)
- (b) Find the acceleration of the car. (3)

5.4 Two blocks of masses m_1 and m_2 , with $m_1 > m_2$, are placed in contact with each other on a frictionless, horizontal surface as in Active Figure 5.12a. A constant horizontal force F is applied to m_1 as shown. Draw free body diagram of each box.

(6)

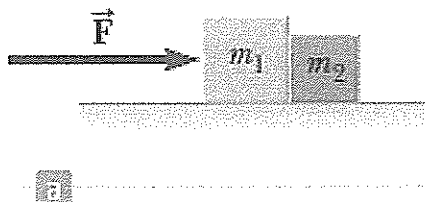

Useful Information

$$v_{yf} = v_{yi} + a_x t, \quad v_{yf}^2 = v_{yi}^2 + 2a_x(x_f - x_i), \quad x_f = x_i + v_x t + \frac{1}{2} a_x t^2, \quad x_f = x_i + \frac{1}{2} (v_{xi} + v_{xf}) t$$

$$\Delta x = x_f - x_i, \quad v_{x,avg} = \frac{\Delta x}{\Delta t}, \quad v_{avg} = \frac{d}{t}, \quad v_x = \frac{dx}{dt}, \quad a_{x,avg} = \frac{\Delta v}{\Delta t}, \quad a_x = \frac{dv_x}{dt}$$

$$W = F \Delta r \cos \theta, W = F \Delta r, \vec{A} \cdot \vec{B} = AB \cos \theta, W = \vec{F} \cdot \Delta r, K = \frac{1}{2} m v^2, W = \Delta K, U_g = mgy, U_s = \frac{1}{2} k x^2, W = \Delta U_g, E_{mech} = K + U, \Delta E_{int} = f_k d,$$