

UNIVERSITY OF FORT HARE

**ELEMENTARY ELECTRICITY
PHY 125F**

SUPPLEMENTARY EXAMINATIONS

OCTOBER / NOVEMBER

YEAR

2024

Time: 2 hours
Subject: PHY 125F
Marks: 100

This paper consists of 7 pages, including the cover page

Internal Examiners
Ms. Y. Mapantsela

Moderator
Mr. T. Mthimunye

INSTRUCTIONS

Answer ALL Questions.
Useful information on the back page.
Round off your answers to TWO decimal places.

Question 1 (25)

1. Two-point charges are 4 cm apart. They are moved to a new separation of 2 cm. By what factor does the resulting mutual force between them change?
 - a) $\frac{1}{2}$
 - b) 2
 - c) $\frac{1}{4}$
 - d) 4

2. Electric field is dimensionally equivalent to which of the following? (2)
 - a) N.m/C
 - b) N/C
 - c) $\text{N.m}^2/\text{C}^2$
 - d) N/C^2

3. The number of electric field lines passing through a unit cross sectional area is indicative of: (2)
 - a) Field direction
 - b) Charge density
 - c) Field strength
 - d) Charge motion

4. If a certain resistor obeys Ohm's Law, its resistance will change: (2)
 - a) As the voltage across the resistor changes.
 - b) As the current through the resistor changes.
 - c) As the energy given off by the electrons in their collisions changes.
 - d) None of the above, since resistance is a constant for the given resistor.

5. By what factor is the resistance of a copper wire changed when its temperature is increased from 20°C to 120°C ? The temperature coefficient of resistivity for copper = $3.9 \times 10^{-3} (\text{C})^{-1}$. (2)
 - a) 0.70Ω
 - b) 1.06Ω
 - c) 10.31Ω
 - d) 13.8Ω

(3)

6. Which process will double the power given off by a resistor?
- Doubling the current while doubling the resistance
 - Doubling the current by making the resistance half as big
 - Doubling the current by doubling the voltage
 - Doubling the current while making the voltage half as big.

(2)

7. What is Kirchoff's 1st equation for this junction?

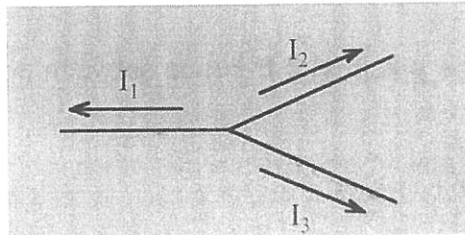

- $I_1 = I_2 + I_3$
- $I_2 = I_1 + I_3$
- $I_3 = I_1 + I_2$
- $I_1 + I_2 + I_3 = 0$

(2)

8. The unit of capacitance, the farad, is dimensionally equivalent to which of the following?

- V/C
- V.C
- J/V
- C/V

(2)

9. Increasing the voltage across the two plates of a capacitor will produce what effect on the capacitor?

- Increase charge
- Decrease charge
- Increase capacitance
- Decrease capacitance

(2)

10. A $0.25 \mu F$ capacitor is connected to 400 V battery. Find the charge on the capacitor.

- $1.2 \times 10^{-12} C$
- $1.0 \times 10^{-4} C$
- 0.040 C
- 0.020 C

(2)

11. Doubling the voltage across a parallel plate capacitor does not double which of the

following?

- a) The charge
- b) The electric field between the plates
- c) The energy stored
- d) Both a and b

(2)

12. Three capacitors of 1.0 , 1.5 , and $2.0 \mu F$ are connected in series. Find the combined capacitance.

- a) $4.5 \mu F$
- b) $4.0 \mu F$
- c) $2.2 \mu F$
- d) $0.46 \mu F$

(2)

Question 2 (25)

1. A battery has an Emf of 12.0 V and an internal resistance of 0.50Ω . Its terminals are connected to a load resistance of 3.00Ω .

(a) Find the current in the circuit and the terminal voltage of the battery.

(4)

(b) Calculate the power delivered to the load resistor, the power delivered to the internal resistance of the battery and the power delivered by the battery.

(6)

2. The circuit in the drawing contains three identical resistors. Each resistor has a value of 10.0Ω . Determine the equivalent resistance between the points a and b , b and c , and a and c .

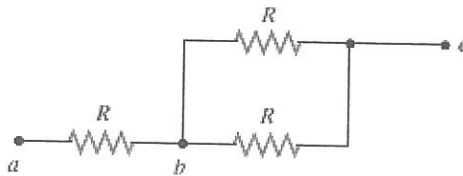

(5)

3. Find the equivalent resistance between points A and B in the drawing.

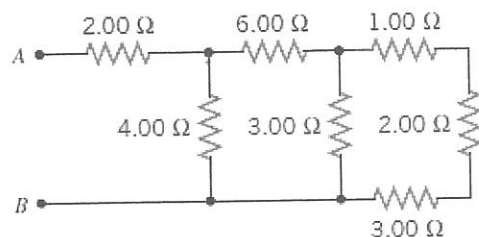

(5)

4. In 2.0 s, 1.9×10^{19} electrons pass a certain point in a wire. What is the current I in the wire? (5)

Question 3 (20)

1. A proton is moving parallel to a uniform electric field. The electric field accelerates the proton and increases its momentum to $5 \times 10^{-23} \text{ N}\cdot\text{s}$ from $1 \times 10^{-23} \text{ N}\cdot\text{s}$ in a time of $6 \times 10^{-6} \text{ s}$. What is the magnitude of the electric field? (10)
2. Three charges are fixed to an x, y coordinate system. A charge of $+18 \mu\text{C}$ is on the y axis at $y = +3.0 \text{ m}$. A charge of $-12 \mu\text{C}$ is at the origin. Last, a charge of $+36 \mu\text{C}$ is on the x axis at $x = +3.0 \text{ m}$. Determine the magnitude and direction of the net force on the charge at $x = +3.0 \text{ m}$. (10)

Question 4 (20)

1. Explain the process of charging a capacitor, include diagrams. (10)
2. A circuit contains a 48-V battery and a single light bulb whose resistance is 240Ω . A second identical, light bulb can be wired either in series or in parallel with the first one. Determine the power delivered to a single bulb when the circuit contains (a) only one bulb, (b) two bulbs in series, and (c) two bulbs in parallel.

(10)

Question 5 (10)

1. Find the equivalent resistances R_{CD} , R_{EF} and R_{AB}

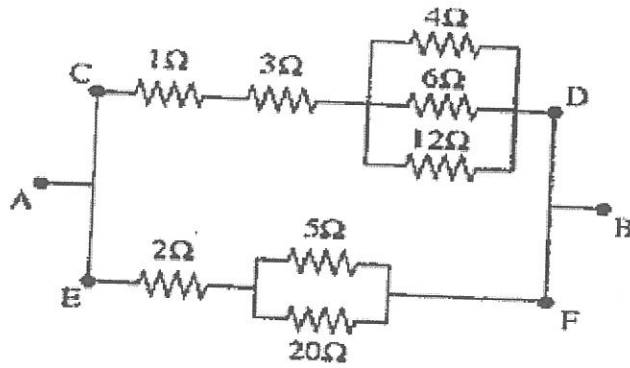

(10)

***** THE END! *****

USEFUL INFORMATION

<u>Name</u>	<u>Symbol</u>	<u>Value</u>
1. Electron Charge	e	$1.6 \times 10^{-19} \text{ C}$
2. Mass of Electron	m_e	$9.11 \times 10^{-31} \text{ kg}$
3. Mass of Proton	m_p	$1.68 \times 10^{-27} \text{ kg}$
4. Coulombs constant	k	$9 \times 10^9 \text{ N.m}^2 \text{ C}^{-2}$
5. Resistivity of Copper	ρ	$1.72 \times 10^{-8} \Omega \text{ m}$
6. Resistivity of Tungsten	ρ	$5.6 \times 10^{-8} \Omega \text{ m}$
7. Gravitational acceleration	g	10 m/s^2

Equations

1. $V = I.R$
2. $\Delta p = F \Delta t$
3. $F = qE$
4. $F = k|Q_1||Q_2| / r^2$
5. $C = Q/\Delta V$
6. $P = V^2/R$
7. $P = I^2R$

