

University of Fort Hare
Physical sciences method
Supplementary exam
PMS 411 and PHM 412
June 2025

Internal Examiners: Ms B. Mzilikazi

Dr C. Mutanho

External moderator: Dr F. George (CPUT)

Marks: 100

Duration of this exam: 3 hours.

Instructions

This assessment has four questions, answer all.

Show all the calculations where necessary.

Question 1 (28 marks)

Your grade 11 learners did not do well in an assessment that you gave them, provide suitable solutions for a class revision for the following assessment task:

1.1 Choose the correct response from the list of options and give a thorough justification for your response of choice.

1.1.1 Which conjugate acid-base pair is shown in the following equation?



- A. H_2O & H_3O^{+}
- B. H_2S & H_3O^{+}
- C. H_2O & H_2S

D. H₂S & H₂ (3)

1.1.2 Which of the following substances can behave as an ampholyte?

A. H₂SO₄

B. HSO₄⁻¹

C. SO₂

D. SO₄²⁻

(3)

1.1.3 How many moles are there in 5.6 dm⁻³ of chlorine gas at STP?

A. 2.8 mol

B. 125.44 mol

C. 0.25 mol

D. 11.3 mol

(3)

1.2 Consider the following acid-base reaction that occurs in an indicator, HIn:



1.2.1 Define an acid according to Lowry-Bronsted theory. (2)

1.2.2 Is the indicator (HIn) an acid or a base in the reaction? Give a reason for your answer. (2)

1.2.3 Provide the formula of X. (2)

1.3 The indicator has the following colours in different solutions:

Acid	Neutral	Base
Yellow	Green	Blue

1.3.1 What will the colour of the indicator be when it is added to a sodium hydroxide (NaOH) solution? Choose from 'YELLOW', 'NEUTRAL', or 'GREEN' in the table. (1)

1.3.2 A school laboratory has 100cm³ of hydrochloric acid (HCl) solution with a concentration of 0.9 mol.dm⁻³ available.

1.3.2.1 Define concentration in words. (2)

1.3.2.2 Calculate the number of moles of hydrochloric acid (HCl) present in 100cm³ of this solution. (3)

All of the 100cm³ of HCl solution is allowed to react with 3.5 g of an unknown metal carbonate (MCO₃) according to the balanced equation:



The hydrochloric acid solution is found to be in EXCESS.

The EXCESS hydrochloric acid (HCl) is neutralized by 25cm³ of a sodium hydroxide (NaOH) solution with a concentration of 0.8 mol.dm⁻³.

The neutralization reaction of the excess HCl solution is shown below:



1.3.2.3 Determine by calculation the symbol of the unknown symbol metal, M. (7)

Question 2 (23 marks)

Electrostatics is one of the subjects that grade 12 learners are struggling with, according to a review of the National Diagnostic Reports (NDR) for grade 12. One suggestion is that teachers give a comprehensive lesson on this subject in grade 11 and conduct a thorough revision in grade 12. From the report, it has also been noted that some misconceptions are made by teachers when they are teaching. Provide marking guide for revision with grade 12 physical sciences class.

2.1 Choose the correct response from the list of options and give a thorough justification for your response of choice.

2.1.1 Two identical point charges, A and B have charges of -3pC and +9pC respectively and are allowed to touch and then moved apart. What is the new charge on each sphere in pC? (3)

	Charge A	Charge B
A.	+3	-9
B.	+3	+3
C.	-3	-3
D.	0	0

2.1.2 A positively charged object has...

- A. more electrons than neutrons.
- B. more protons than neutrons.
- C. equal amounts of protons and electrons.
- D. more protons than electrons. (3)

2.1.3 The electric field at a point is defined as ...

- A. the region in space where an electric charge experiences an electrostatic force.
- B. the force per unit charge.
- C. a measure of the force acting on a unit positive charge inside an electric field.
- D. the direction in which a negative test charge would move. (3)

2.2 A and B are two-point charges of $+4\text{nC}$ and $+6\text{nC}$ respectively, separated by 80 mm as shown in the diagram below. C is a point 20 mm east of A.

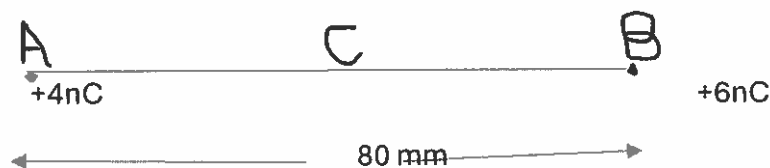

- 2.2.1 Define the term Electric field strength. (2)
- 2.2.2 Draw the electric field pattern between the two-point charges (A and B) as if they were identical in magnitude. (3)
- 2.2.3 Calculate the number of electrons that are added or removed to give a charge of $+5\text{nC}$. (3)
- 2.2.4 Calculate the magnitude and direction of the net electric field strength at point C. (6)

Question 3 (25 marks)

You have studied that CAPS is informed by the South African constitution and the goals of Education for Sustainable Development (ESDs).

3.1 Mention and discuss the FOUR goals of Education for Sustainable Development (ESDs). (12)

3.2 Select TWO of the 17 Sustainable Development Goals (SDGs) and explain how you would address them in any grade Physical Sciences topic. (8)

~~3.3 The effects of climate change are increasingly evident in our lives. As a result, climate change has become a hot topic in many curricula around the world. Select any topic from the Physical Sciences content and show how you would address the environmental issues such as climate change in that topic.~~ (5)

Question 4 (24 marks)

Assessment is defined as a process that measures a learner's attainment of knowledge in a subject by collecting, analyzing and interpreting data.

4.1 Create an assessment task focusing on Electric Circuits. Following Bloom's taxonomy, your questions should target the following components:

- Knowledge recall (2)
- Understanding (2)
- Application (2)
- Analysis (3)
- Synthesis (3)
- Evaluation (4)

4.2 The circuit diagram below shows a battery with an emf of 12V and an internal resistance of 0.5Ω connected to three resistors, a light bulb, a switch, an ammeter and connecting wires. The ammeter and connecting wires have negligible resistance.

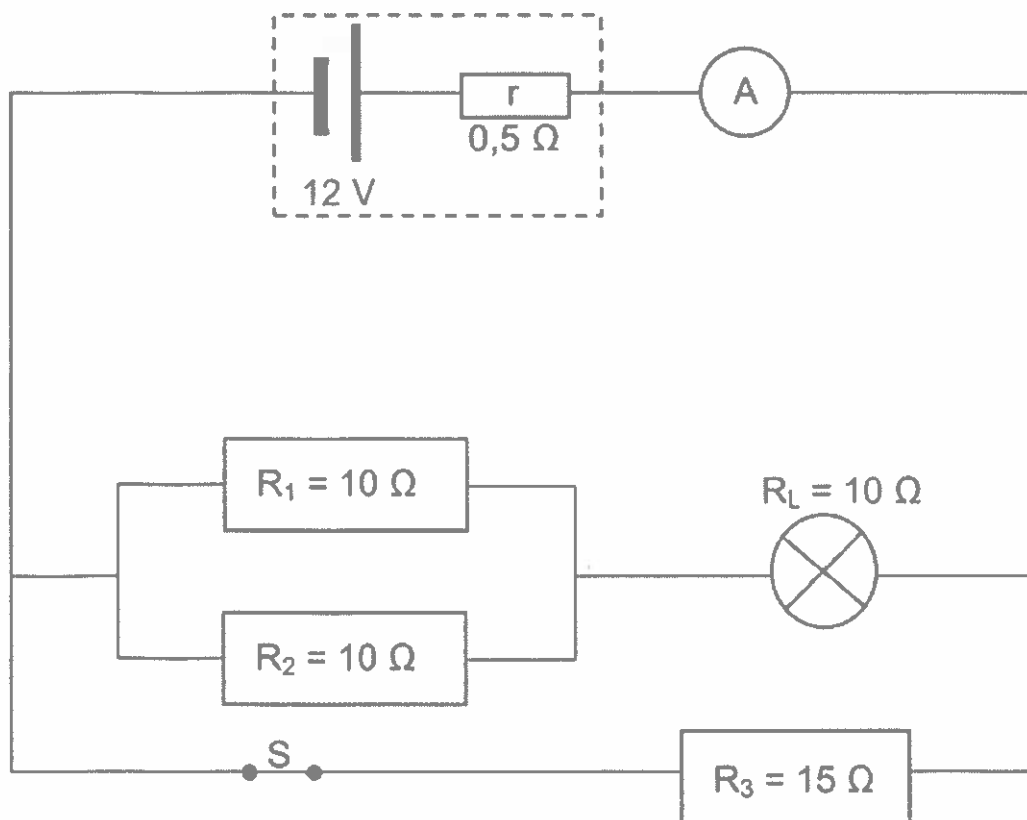

4.2.1 Provide a marking guide for the following task and show mark allocation:

- 4.2.1.1 the total external resistance of the circuit. (5)

4.2.1.2 the reading on the ammeter.

(3)

[TOTAL: 100]
