

UNIVERSITY OF FORT HARE

**ELECTROMAGNETISM
PHY 123**

DEGREE EXAMINATIONS

OCTOBER / NOVEMBER

YEAR

2024

Time: 2 hours
Subject: PHY 123
Marks: 100

This paper consists of 5 pages including the cover page

Internal Examiners
Ms. L. Ndevu

Moderator
Dr. N. Lethole

INSTRUCTIONS

Answer ALL Questions.
Useful information on the back page.
Round off your answers to TWO decimal places.

Question 1 (20)

1. In the figure below, the charges on the two metal spheres and the ebonite rod create an electric field at the spot indicated. This field has a magnitude of 2.0 N/C and is directed as in the drawing. Determine the force on a charge placed at that spot, if the charge has a value of (a) $q_0 = +18 \times 10^{-8} \text{ C}$ and (b) $q_0 = -24 \times 10^{-8} \text{ C}$.

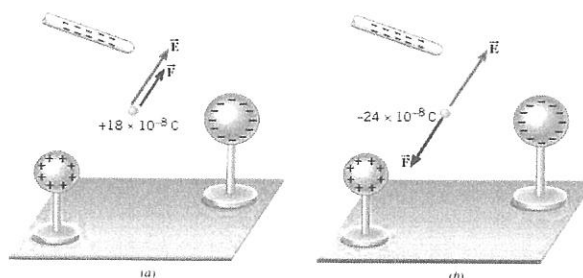

(6)

2. Two particles, with identical positive charges and a separation of $6 \times 10^{-2} \text{ m}$ are released from rest. Immediately after the release, particle 1 has an acceleration whose magnitude is $a_1 = 10 \times 10^2 \text{ m/s}^2$, while particle 2 has an acceleration whose magnitude is $a_2 = 16 \times 10^3 \text{ m/s}^2$. Particle 1 has a mass of $12.00 \times 10^{-6} \text{ kg}$. Determine the following:
- (a) The charge on each particle (6)
(b) The mass of particle 2. (4)
3. Two small identical conducting spheres are placed with their centers 0.50 m apart. One is given a charge of $15 \times 10^{-9} \text{ C}$, the other a charge of $20 \times 10^{-9} \text{ C}$.
- (a) Find the electrostatic force exerted on one sphere by the other. (2)
(b) The spheres are connected by a wire. Find the electrostatic force between the two after equilibrium is reached. (2)

Question 2 (20)

1. A battery has an Emf of 12.0 V and an internal resistance of 0.50 Ω . Its terminals are connected to a load resistance of 3.00 Ω .
- (a) Find the current in the circuit and the terminal voltage of the battery. (4)
(b) Calculate the power delivered to the load resistor, the power delivered to the internal resistance of the battery and the power delivered by the battery. (6)

2. The circuit in the drawing contains three identical resistors. Each resistor has a value of 10.0Ω . Determine the equivalent resistance between the points a and b, b and c, and a and c.

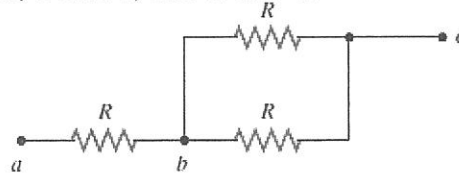

(5)

3. Find the equivalent resistance between points A and B in the drawing.

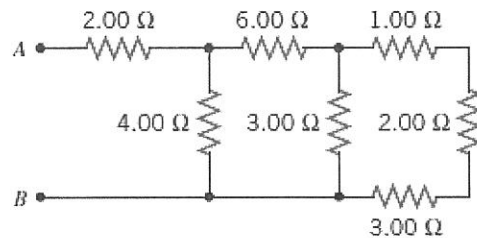

(5)

Question 3 (20)

1. A proton is moving parallel to a uniform electric field. The electric field accelerates the proton and increases its momentum to $5 \times 10^{-23} \text{ N s}$ from $1 \times 10^{-23} \text{ N s}$ in a time of $6 \times 10^{-6} \text{ s}$. What is the magnitude of the electric field? (10)
2. Three charges are fixed to an x, y coordinate system. A charge of $+18 \mu\text{C}$ is on the y axis at $y = +3.0 \text{ m}$. A charge of $-12 \mu\text{C}$ is at the origin. Last, a charge of $+36 \mu\text{C}$ is on the x axis at $x = +3.0 \text{ m}$. Determine the magnitude and direction of the net force on the charge at $x = +3.0 \text{ m}$. (10)

Question 4 (20)

1. Explain the process of charging a capacitor, include diagrams. (10)
2. A circuit contains a 48-V battery and a single light bulb whose resistance is 240Ω . A second identical, light bulb can be wired either in series or in parallel with the first one. Determine the power delivered to a single bulb when the circuit contains (a) only one bulb, (b) two bulbs in series, and (c) two bulbs in parallel. (10)

Question 5 (20)

1. The ammeter shown in the following figure reads 2.00 A. Find I_1 , I_2 and ϵ .

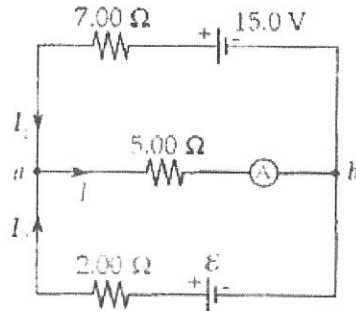

(10)

2. Find the equivalent resistance of the circuit below and the current from the battery.

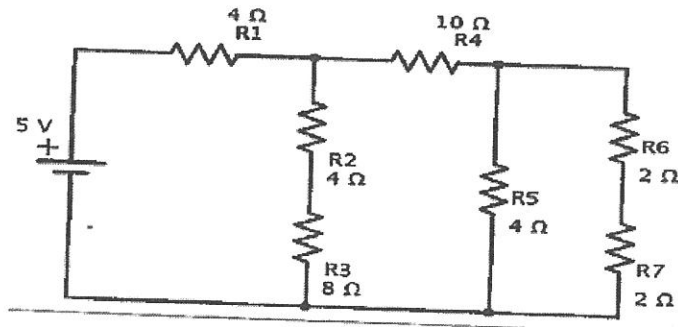

(10)

******* THE END! *******

USEFUL INFORMATION

<u>Name</u>	<u>Symbol</u>	<u>Value</u>
1. <i>Electron Charge</i>	e	$1.6 \times 10^{-19} \text{ C}$
2. <i>Mass of Electron</i>	m_e	$9.11 \times 10^{-31} \text{ kg}$
3. <i>Mass of Proton</i>	m_p	$1.68 \times 10^{-27} \text{ kg}$
4. <i>Coulombs constant</i>	k	$9 \times 10^9 \text{ N.m}^2 \text{ C}^{-2}$
5. <i>Resistivity of Copper</i>	ρ	$1.72 \times 10^{-8} \Omega \text{ m}$
6. <i>Resistivity of Tungsten</i>	ρ	$5.6 \times 10^{-8} \Omega \text{ m}$
7. <i>Gravitational acceleration</i>	g	10 m/s^2

Equations

1. $V = I.R$
2. $\Delta p = F \Delta t$
3. $F = qE$
4. $F = k|Q_1||Q_2| / r^2$
5. $C = Q/\Delta V$
6. $P = V^2/R$
7. $P = I^2 R$

